

Titan PX-1200 Energy Recovery Device – Test Results from the Inima Los Cabos Mexico Seawater RO Facility

Authors:

Richard Stover, Energy Recovery, Inc.
Jeremy Martin, Energy Recovery, Inc.

Abstract

The Energy Recovery, Inc. (ERI[®]) PX Pressure Exchanger[®] energy recovery device recovers hydraulic energy from the high-pressure reject stream from a reverse osmosis (RO) system and transfers it to low-pressure feedwater. Pressurized feedwater from the PX device is sent to the membrane feed, merging with a stream of pressurized water from a high-pressure pump. This significantly reduces the duty of the high-pressure pump. The PX device operates at extremely high efficiency – up to 98 percent – and itself consumes no electrical power. Therefore, the overall energy consumption of a seawater RO process is cut in half or less compared to a system operating with no energy recovery or by 15 to 30% compared to a system operating with state-of-the-art centrifugal energy recovery devices. In addition, PX technology gives the operator the flexibility to vary the RO system recovery rate to maximize process productivity and energy efficiency over a wide range of feed conditions.

The first PX device sold commercially in 1997 – the PX-40 – was the product of at least ten years of development effort. It was made with ceramic components, a material with extremely high strength, high durability and immunity to corrosion that has remained the material of choice for this application. The next generation PX device – the PX-220 – has been operating in the field since 2002 with improved performance and reliability. With a unit capacity of 50 m³/hr or 220 gpm, it is deployed in arrays to serve the largest seawater RO trains in operation. PX technology has become the most popular positive-displacement energy recovery method in RO.

ERI has continued aggressive research and development of PX technology to achieve higher-capacity, better-performing devices. In October 2007, ERI announced the successful development of the Titan PX-1200[™]. This device was designed to operate at flow rates up to 273 m³/hr or 1,200 gpm. A prototype device will be in operation in the Inima seawater RO facility in Los Cabos, Mexico starting in October 2008. The authors present design considerations and performance results from the facility for the Titan device. These are compared to the performance of arrays of PX-220 devices also in operation in the facility.

Process Description

The Los Cabos desalination facility in Mexico is a seawater reverse osmosis plant with a nominal production capacity of 17,280 m³/day and a maximum production capacity of 20,736 m³/day. The plant started production in December 2006. As of September 2008, it is the largest membrane desalination facility in Mexico. Its unique design offers high operational flexibility, allowing it to work over a wide range of feedwater salinities from 13,000 to 35,000 mg/l.

DRAFT

The SWRO equipment includes the following:

- four (4) segmented ring centrifugal pumps with motors driven by variable frequency drives
- four circulation pumps with motors driven by variable frequency drivers
- four sets of energy recovery devices
- two-hundred twenty membrane pressure vessels with seven elements each, arranged in eleven racks

The high-pressure pumps feed a common header which, in turn, feeds the 11 membrane racks. The racks of PX devices with dedicated circulation pumps are fed from a common collector pipe supplied with reject from the membrane racks. The circulation pumps then feed the high-pressure collector pipe. This pressure-center design allows the plant operators to remove individual high-pressure pumps, membrane racks or circulation pump / PX device racks from service without halting the plant's overall production. In addition to the flexibility provided by the pressure center design, the variable frequency drivers allow adjustment of the output of the high-pressure and circulation pumps.¹

Energy Recovery Devices

The Los Cabos plant utilizes ERI[®] PX Pressure Exchanger[®] energy recovery devices. These devices recover pressure energy from the concentrate reject stream of the SWRO membranes and return it to the membrane feed stream. The positive displacement pressure transfer mechanism used in these devices is similar to that in reciprocating pumps, assuring high efficiency despite flow and pressure variations.² This feature contributes to the flexible operation of the Los Cabos plant.

The plant is equipped with four sets of five model PX-220 pressure exchanger devices. Each group of five devices are mounted on manifolds to operate in parallel. A photo a PX device array at the plant is shown in Figure 1.

Figure 1 – PX-220 Energy Recovery Device Array



DRAFT

The pressure-transfer efficiency of a PX unit or PX device array can be calculated with Equation (1):

$$\text{PX efficiency} = \frac{\sum(\text{Pressure} \times \text{Flow})_{\text{OUT}}}{\sum(\text{Pressure} \times \text{Flow})_{\text{IN}}} \times 100 \% \quad (1)$$

The positive-displacement mechanisms employed by all isobaric ERDs provide high hydraulic-transfer efficiency but also allow some mixing of the concentrate and feedwater. The degree of mixing is a characteristic of the particular ERD and a function of the ratio of concentrate and feedwater flow rates to the ERD. Mixing can be quantified as a salinity of the membrane feed stream compared to the salinity of the system feed stream.

Process Performance

The Los Cabos process has been in operation since later 2006. Process performance data was collected in August 2007. A sampling of the data is presented for three hypothetical SWRO trains in Table 1 with reference to the process locations indicated in Figure 2.

Table 1 – SWRO Process Data

		A	B	C	D	E	F	G	H	
TRAIN 1	FLOW	m3/hr	463	225	238	225	428	202	226	226
	PRESSURE	bar	2.0	2.0	1.8	58.4	60.3		59.4	1.2
	CONDUCTIVITY	uS/cm	48.3	48.3	48.3	49.2	48.7		88.7	87.7
TRAIN 3	FLOW	m3/hr	467	225	242	225	433	207	226	226
	PRESSURE	bar	2.0	2.0	1.8	58.4	60.3		59.4	1.2
	CONDUCTIVITY	uS/cm	48.3	48.3	48.3	50.4	49.2		91.4	89.3
TRAIN 4	FLOW	m3/hr	464	225	239	225	429	202	226	226
	PRESSURE	bar	2.0	2.0	1.8	58.4	60.3		59.4	1.2
	CONDUCTIVITY	uS/cm	48.3	48.3	48.3	49.1	48.6		88.1	87.3

Figure 2 – Schematic Diagram of Hypothetical SWRO Train

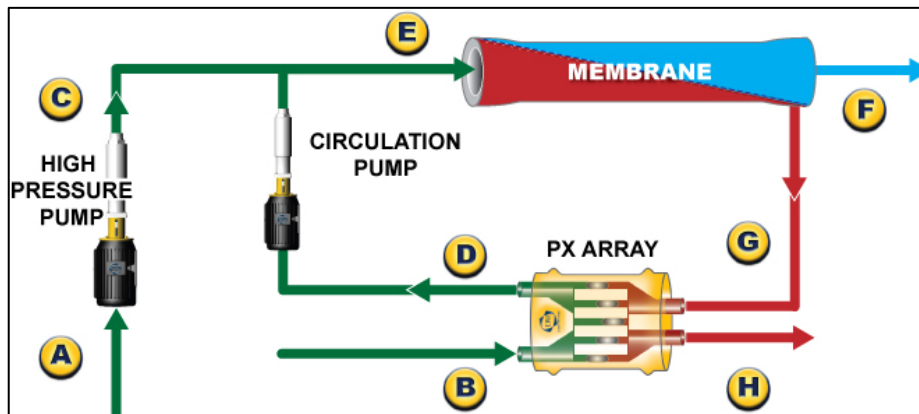

DRAFT

The data in Table 1 indicate that the PX devices are operating with an efficiency of approximately 96.6% and a salinity increase at the membrane feed of approximately 2.3%. The energy transfer efficiency exhibited by these devices far exceeds what could be achieved by centrifugal energy recovery devices such as Pelton turbines or hydraulic turbochargers. This efficiency more than compensates for the slight degree of mixing that occurs in the PX devices.³

PX Titan Installation

Since introducing the PX-220 to the desalination market in 2002, ERI has continued aggressive research and development of PX technology to achieve higher-capacity, better-performing devices. In October 2007, ERI announced the successful full-flow, full-pressure laboratory test of the Titan PX-1200™. A photograph of the device in testing is shown in Figure 3.

Figure 3 – ERI Titan PX-1200 Energy Recovery Device on Test Stand



The Titan PX-1200 is built into a standard 16-inch diameter, 1200-psi membrane pressure vessel. The unit contains a single cartridge in which pressure exchange occurs. The cartridge includes a ceramic rotor and two ceramic endcovers. The Titan device was designed to operate at flow rates up to 273 m³/hr or 1,200 gpm. Its efficiency performance on ERI's test stand is summarized and compared to that of the PX-220 is given in Figure 4. The efficiency data in Figure 4 is plotted as a function of fractional flow which is the measured flow rate divided by the maximum rated flow of the device. For example, a PX-220 operating at 220 gallons per minute is operating at a fractional flow of 1.0.

Figure 4 – Titan PX-1200 and PX-220 Efficiency on ERI Test Stand

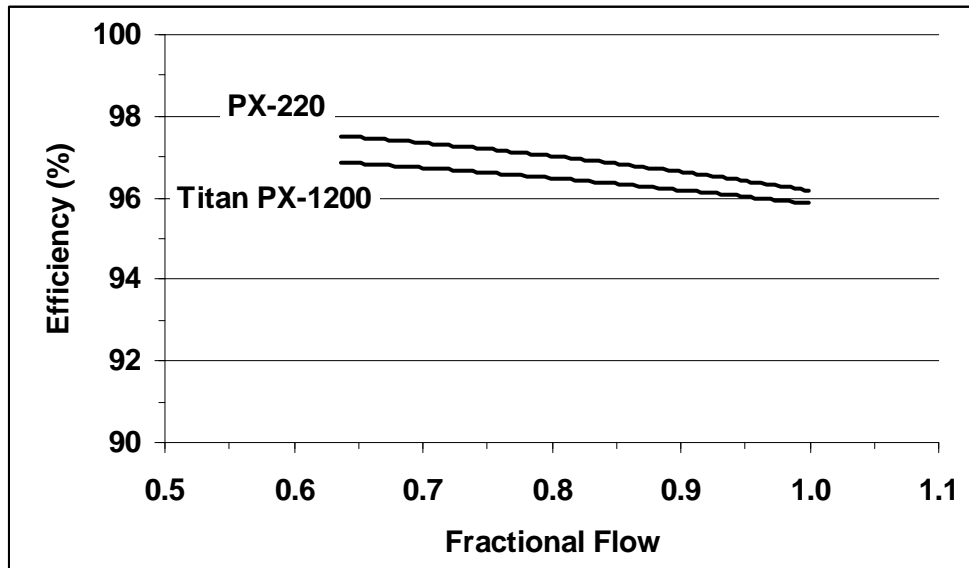

Mixing in the Titan PX-1200 measured on ERI's test stand and adjusted to the salinity increase one would measure at the membrane feed at 50% recovery is 2.0% compared to 2.3% in the PX-220 at fractional flows of 1.0. Note that the performance of individual PX-220 devices on ERI's test stand is nearly exactly the same as that of the PX-220 device arrays in the Los Cabos plant.

A prototype device will be installed in the Los Cabos facility in place of a 5-unit array of PX-220 devices. The installation is scheduled for early October 2008. It will be the first Titan device in operation in seawater.

Summary

The Los Cabos SWRO process was designed with a pressure center configuration for maximum flexibility to accommodate a wide range of feed salinities. Put into operation in December 2006, the plant is the largest SWRO process in Mexico today. The process design includes arrays of PX-220 energy recovery devices which further support process flexibility by operating at high efficiency over a broad range of flow rates and pressures. One array of five PX-220 devices will be replaced with a Titan PX-1200 device in October 2008. Data from ERI's test stand indicates that the performance of the Titan device is comparable to that of PX-220 devices. This will be the first Titan device in operation in seawater.

References

- (1) A. Ordonez, E. Salgado, B. Gutierrez, Seawater Desalination Plant of Los Cabos (Mexico) An Innovative Design, Proceedings of the International Desalination Association World Congress, Maspalomas, Gran Canaria, Spain, October 2007.
- (2) R.L. Stover, Development of a Fourth Generation Energy Recovery Device – A CTO's Notebook, *Desalination*, 165 (2004) 313-321.
- (3) R.L. Stover, Seawater Reverse Osmosis with Isobaric Energy Recovery Devices, *Desalination* 203 (2007) 168-175.