



## PX-220 | PX-180

PX Pressure Exchanger® Energy Recovery Devices

# PX-220 | PX-180

PX Pressure Exchanger® Energy Recovery Devices



The PX-220 | PX-180 is ERI®'s flagship energy recovery device from the 65-Series product family. Designed for the SWRO market, each PX® device handles brine flow rates of 32 - 50 m<sup>3</sup>/hr (140 to 220 gpm), corresponding to permeate flow rates of 630 to 1,000 m<sup>3</sup>/day when operating at 45% recovery. PX devices may be manifolded together to achieve capacity ranges in multiples of single device capacity.

## PREMIUM QUALITY AND ADVANCED TECHNOLOGY OVER ANY OTHER ERD

Based on a rotary positive displacement pump principle, PX Pressure Exchanger technology greatly reduces water production costs by up to 60%. Industry experts have designed and tested PX Pressure Exchanger devices in seawater and brine environments. The PX-220/180 units are encased in industry standard 8" diameter housings proven to provide extended field service life in SWRO applications.

Since its introduction in 1997, PX technology has emerged as the industry standard solution for SWRO desalination. PX devices installed for several years have proven the endurance of the ceramic construction by requiring no routine maintenance when operated for tens of thousands of hours in tough seawater environments. With over 120 combined years of industry experience, ERI has assembled a technical services and support team with exceptional knowledge of RO systems. Our

team members have consulted with dozens of SWRO operators, aiding in design review, on-site training and support.

## HIGH CONSTANT EFFICIENCY

The ERI PX device achieves real energy transfer efficiencies up to 98%, making it the most efficient ERD technology available. The positive displacement mechanism employed by the PX device provides constant ultra high efficiencies over a broad range of flows and pressures. ERI guarantees PX device efficiency to be greater than 95% for most SWRO applications regardless of salinity, temperature or recovery rate variations. This characteristic *differs* from centrifugal devices whose performance declines as flows and pressures shift away from device best efficiency points. High and constant efficiency are significant operating cost advantages over other energy recovery devices on the market.

## CERAMIC COMPONENTS

At the core of the PX device is a cartridge made of tough, engineered corundum (aluminum oxide). This ceramic material is unaffected by chemicals and will not corrode. Its properties are similar to that of sapphire and its hardness exceeds that of many stainless steels by a factor of three. In fact, most PX units taken apart for inspection after years of service exhibit no evidence of wear or deterioration whatsoever.

## FLEXIBLE ARRAYS

By operating multiple PX units in parallel, there is no limitation to the SWRO train size possible with PX technology. 65-Series PX technology has been specified for SWRO plants with permeate production capacities up to 240,000 m<sup>3</sup>/day (63 MGD) and is well suited for even larger plants. Up to 40 PX rotors have been successfully arrayed in a single train and 10 to 16 rotors in parallel are common. In the unlikely event that one or more rotors in an array stop turning, flow safely passes through the stuck rotor allowing a plant operator to wait for a convenient time to service the unit. PX devices in an array can be easily and quickly removed or added, providing flexible capacity.

## QUALITY DESIGN & CONSTRUCTION

Due to harsh conditions and continuous service requirements in SWRO plants, material specification, fabrication and assembly are critical to ensuring ERI's products perform consistently and reliably. Precise machining, inspection and performance testing are con-

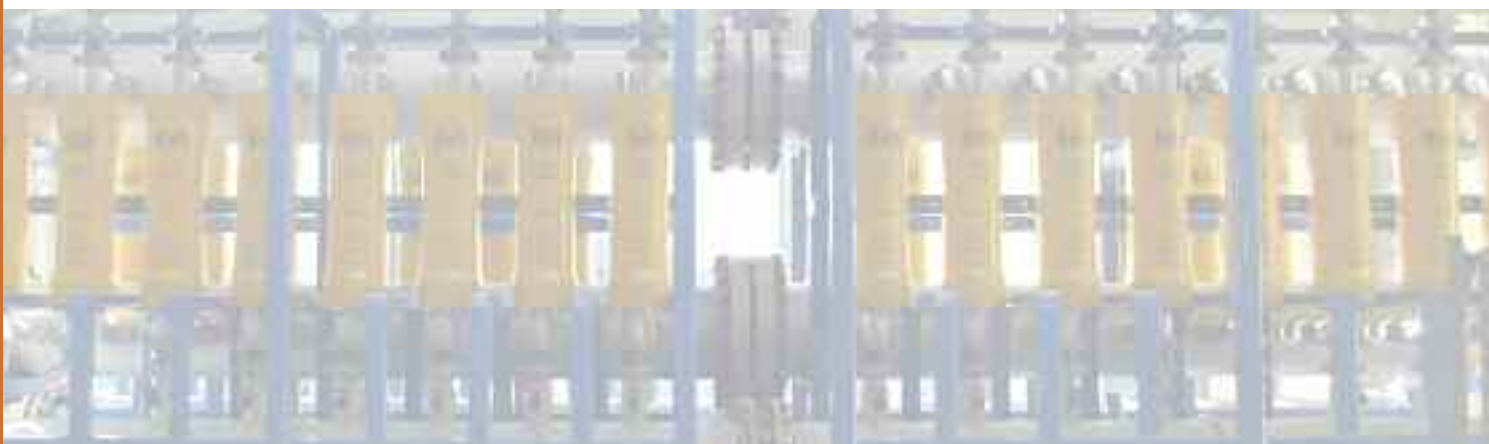



ducted. ERI's Engineering and Manufacturing departments work closely to maintain tight control and quality assurance. With proven reliability and maintenance-free performance, ERI's PX technology is one of the few rotating devices in the world that is backed by a free **five-year** warranty.

### **PROVEN RELIABILITY AND EXPERIENCE**

PX technology has emerged as the industry standard for projects of all sizes; primarily due to the PX device's consistent delivery of energy and maintenance savings – with no excuses about changes in original design envelopes. Over 80 OEMs worldwide have standardized on PX technology with installations from small to medium (in practically every part of the world), to the world's largest desalination plants in Algeria, Australia, China, India, Mexico, Spain, along the Mediterranean Sea and the Middle East.

### **LOWEST LIFECYCLE COSTS**

ERI's global install base saves real money compared to older energy recovery technologies such as Pelton wheels, Francis turbines and turbo chargers.

- Savings at over \$350 Million per year
- Up to 98% efficient
- Proven SWRO power consumption as low as 1.6 kWh/m<sup>3</sup>\*
- Real power savings of over 500 MW worldwide

### **WORLD-WIDE REFERENCES**

ERI has 10 times more operating experience than the next manufacturer of isobaric energy recovery devices.

- Millions of unit hours of proven reliability
- Over 80 OEM's using PX devices with over 6,000 units sold or contracted worldwide
- More than 5,200,000 m<sup>3</sup>/day of capacity installed or under construction
- Multiple 10,000 m<sup>3</sup>/day trains operating for more than three years
- Standard 5 year warranty

### **SIMPLE DESIGN & EASE OF USE**

PX technology offers the simplest approach to isobaric energy recovery available today; only one moving part and no scheduled maintenance. Its ease of use with no artificial intelligence or adaptive control schemes as well as fail-safe design features makes the PX device easy at startup and shutdown.

- Constant high efficiency over entire operating range
- One moving part
- Zero scheduled maintenance
- Smallest installed footprint when compared to other isobaric ERDs
- No pulsation, valves, pistons or timers

### **MATERIALS**

- Alumina Ceramic
- Fiberglass Reinforced Polymer (FRP) internal components
- Industry Standard FRP housing
- AL-6XN<sup>®</sup> Superaustenitic Stainless Steel or equivalent wetted metal components
- Flexible coupling connections for easy installation

\*ADC

AL-6XN<sup>®</sup> is a registered trademark of Allegheny Ludlum Corp.

**External Dimensions and Piping Details**

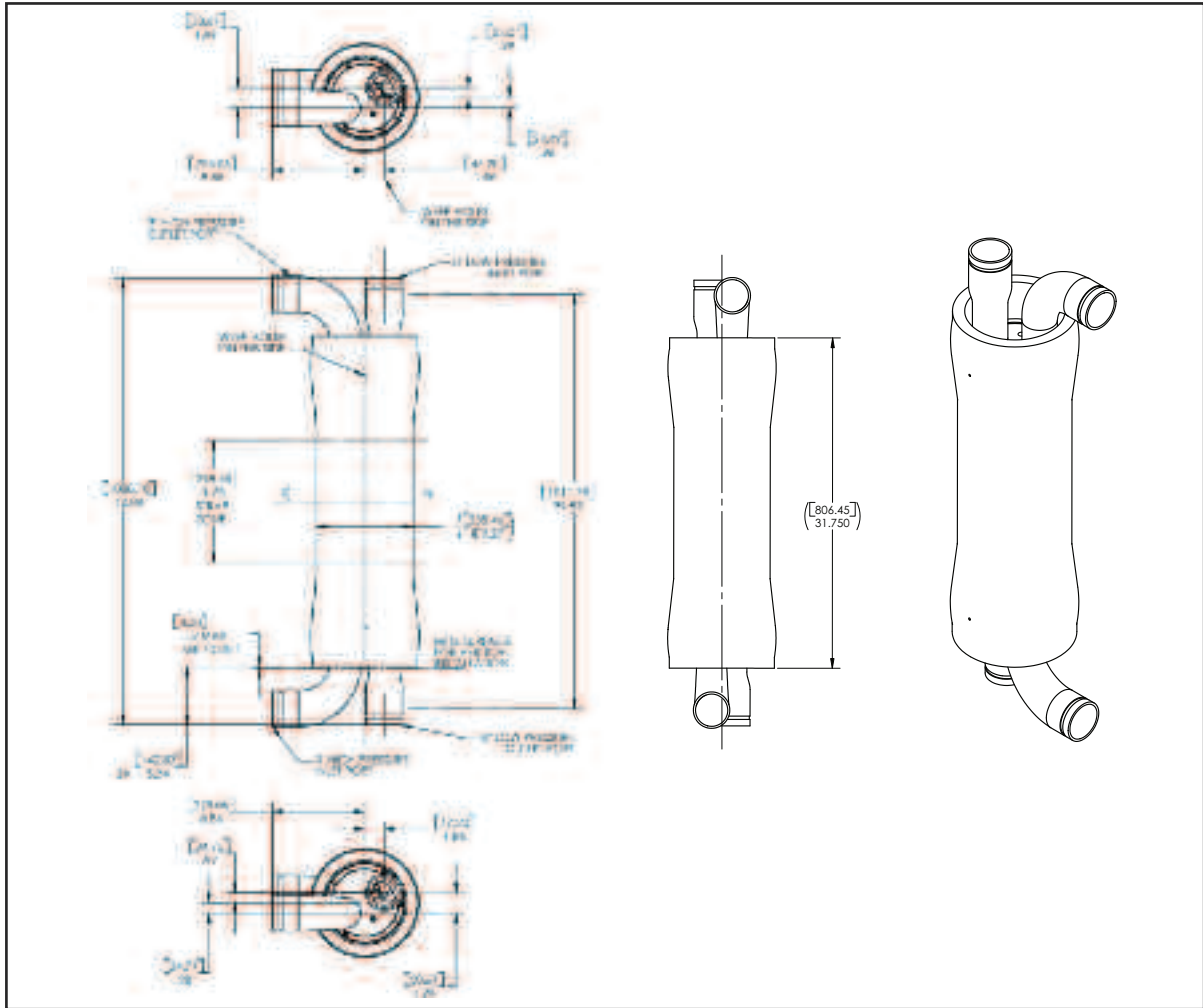

Model	Capacity m³/hr (gpm)	Connections (4) inches	Shipping Dimensions mm (inches)	Shipping Weight kg (lbs)
<b>PX-220</b>	40 – 50 (180 – 220)	3	1219 x 1016 x 483 (48 x 40 x 19)	109 (240)
<b>PX-180</b>	32 – 41 (140 – 180)	3	1219 x 1016 x 483 (48 x 40 x 19)	109 (240)

See ERI Document Number 40009 current revision for assembly dimensions and component bill of materials.

**PROPRIETARY AND CONFIDENTIAL**

THE INFORMATION CONTAINED IN THIS DRAWINGS IS THE SOLE PROPERTY OF ENERGY RECOVERY, INC. ANY REPRODUCTION IN PART OR AS A WHOLE WITHOUT WRITTEN PERMISSION OF ENERGY RECOVERY, INC. IS PROHIBITED

©2009, ENERGY RECOVERY, INC.



Energy Recovery, Inc.  
1908 Doolittle Drive  
San Leandro, CA 94577  
TEL +1 (510) 483-7370  
FAX +1 (510) 483-7371  
EMAIL info@energyrecovery.com  
WEB www.energyrecovery.com



Making Desalination Affordable®



©Energy Recovery, Inc. 2009 All Rights Reserved.  
Design and specifications subject to change without prior notice.  
Doc. No. ERI-PB101EE 2009-02